

Colpo singolo Sequential fire

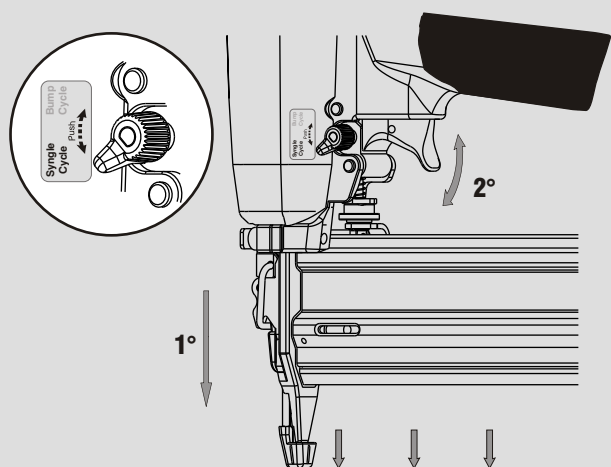

Colpo martello Bump fire

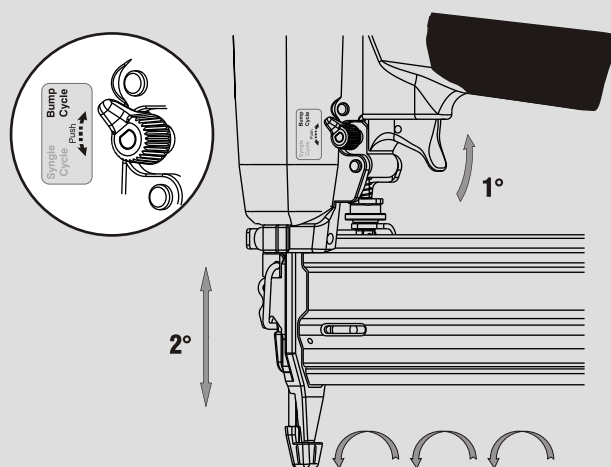

1 - Segnalatore fine stecca Strip end indicator

2 - Puntale Tip

3 - Porta puntale Tip holder

4 - Blocco sparo a caricatore scarico Stop firing device to signal empty magazine

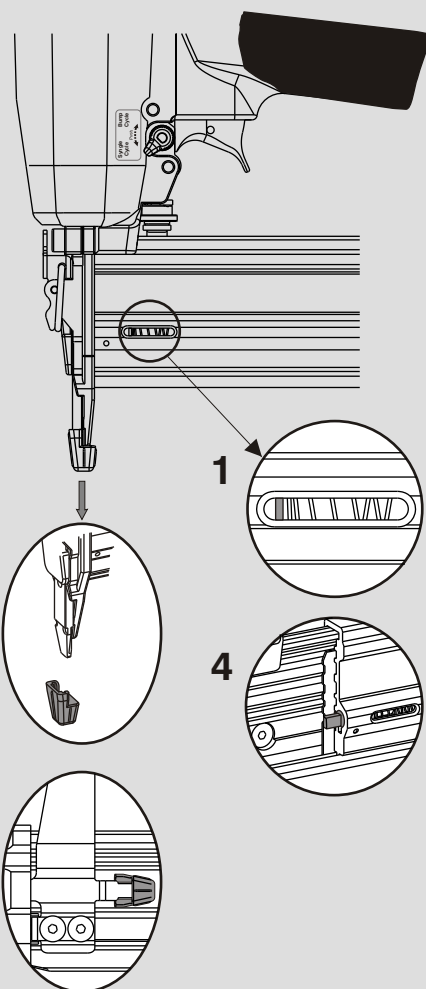

Regolatore di profondità Depth adjustment

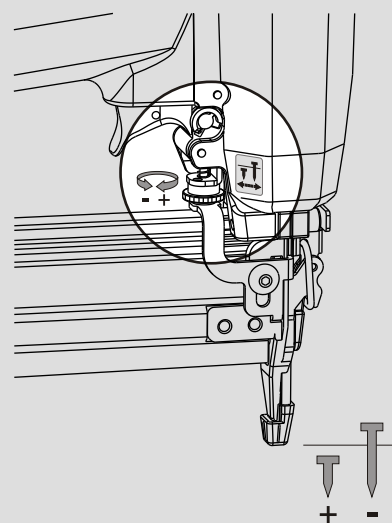

Disinceppamento macchina Quick clearance jammed nails

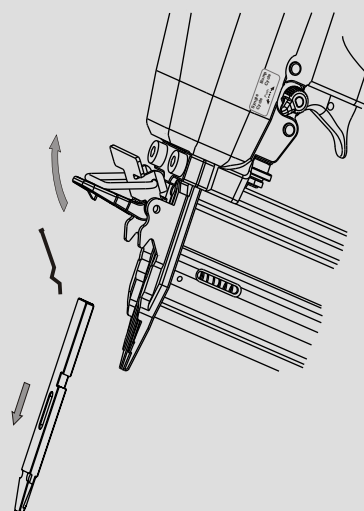

Manuale d'uso, manutenzione e parti di ricambio
Use, maintenance and spare parts manual
Gebrauchsanweisung, Instandhaltungsrichtlinien und Ersatzteile
Manuel d'utilisation, entretien et pièces de rechange
Manual de uso, mantenimiento y repuestos

Parte 2
Part 2
Teil 2
Partie 2
Part 2

Manual de utilização, manutenção e partes sobresselentes
Handleiding voor gebruik, onderhoud en reservedelslste
Brugsanvisning, vedligeholdelse og reservedelslste

Parte 2
Deel 2
Del 2



12.50

cod. 1421200

1421200_1250_2 220708 IV

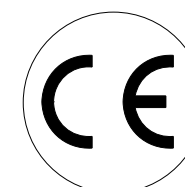

Dati tecnici Technical data Technische daten	Données techniques Datos técnicos	Dados técnicos Technischegegevens Tekniske data
--	--------------------------------------	---

Misure impieghiabili mm Usable lengths mm Gebrauchliche Längen mm	Mesures utilisables mm Medidas que se pueden emplear mm	Medidas que se podem utilizar mm Te gebruiken engtes in mm Brugbare laengder i mm	20 ÷ 50
Capacità caricatore n° punti Magazine capacity No. of fasteners Magazinkapazität Nägel	Capacité chargeur n° de points Capacidad cargador n° puntos	Capacidade carregador n° pontos Capaciteit magazijn in aantal spijkers Kapacitet af magasin antal klemme	110
Pressione d'esercizio Working pressure Betriebsdruck	Pression de fonctionnement Presión de trabajo	Pressao de trabalho Werkdruk Arbejds tryk bar	5 ÷ 7,5 bar 70 ÷ 105 psi
Consumo aria litri/colpo Air consumption litres/shot Luftverbrauch Liter/Schlag	Consommation air litre/coup Consumo aire-litros/golpe	Consumo ar litro/golpe Luchtverbruik liter/schot Luftforbrug liter/skud	0,54
Peso kg Weight kg Gewicht kg	Poids kg Peso kg	Peso kg Gewicht in kg Vaegt kg	1,35
Dimensioni (AxH) mm Dimensions mm Größe mm	Dimension mm Dimensiones mm	Dimencoes mm Afmetingen in mm Dimensioner mm	229x58x250

EN 12549 :1999 ISO 11201 :1995		L _{pA,1s} (rif. 20µPa)	
Pressione sonora in pos. operatore Sound pressure at the workstation Lärmintensität am Arbeitsplatz	Pression acoustique près de l'opérateur Presión sonora en posición encargada	Intensidade sonora perto do operador Geluidssterkte op de werkplek Lydstyrke på operatorposten	82,9 dB(A)

EN 12549 :1999 ISO 3744 :1994		L _{WA,1s} (rif. 1pW)	
Potenza sonora emessa Emitted sound power Ausgestrahlte Lärmintensität	Puissance acoustique émise Potencia sonora emitida	Potência sonora emitida Utgestraalde geluidssterkte Udsendt lydstrykke	92,5 dB(A)

EN 28662 :1992 ISO 5349 :1986 ISO 8662 -11			Sequential a _{h,w}
Valore medio ponderato di vibrazione sull'impugnatura Weighted mean value of vibration on the grip Mitteler Vibrationswert, am Griff Gemessen	Valeur moyenne pondérée de vibration mesurée sur la poignée Valor medio ponderado de vibracion medida en la empunadura	Valor medio ponderado de vibracao medida no punho Gewogen gemiddelde vibratiewaarde Middelvaerdi af vibrationer pa handtaget	2,77 m/s²
			Bump a _{h,w} 3,06 m/s²

Tipo di punto
Type of fastener
Befestigungselement
Type d'agrafe
Tipo de punto
Tipo de ponto
Type nietjes
Tilspændingstype

Brads 12

1,00x1,25

1,9

20 — — 3/4"

25 — — 1"

30 — — 1-3/16"

32 — — 1-1/4"

38 — — 1-1/2"

40 — — 1-9/16"

45 — — 1-3/4"

50 — — 2"

Head width: .075"

Thickness: .040"

Width: .050"

Gauge: 18

Parti di ricambio - Spare parts - Ersatzteile - Pièces de rechange - Piezas de repuesto
- Partes sobresselentes - Tabel te raadplegen - Reservedele

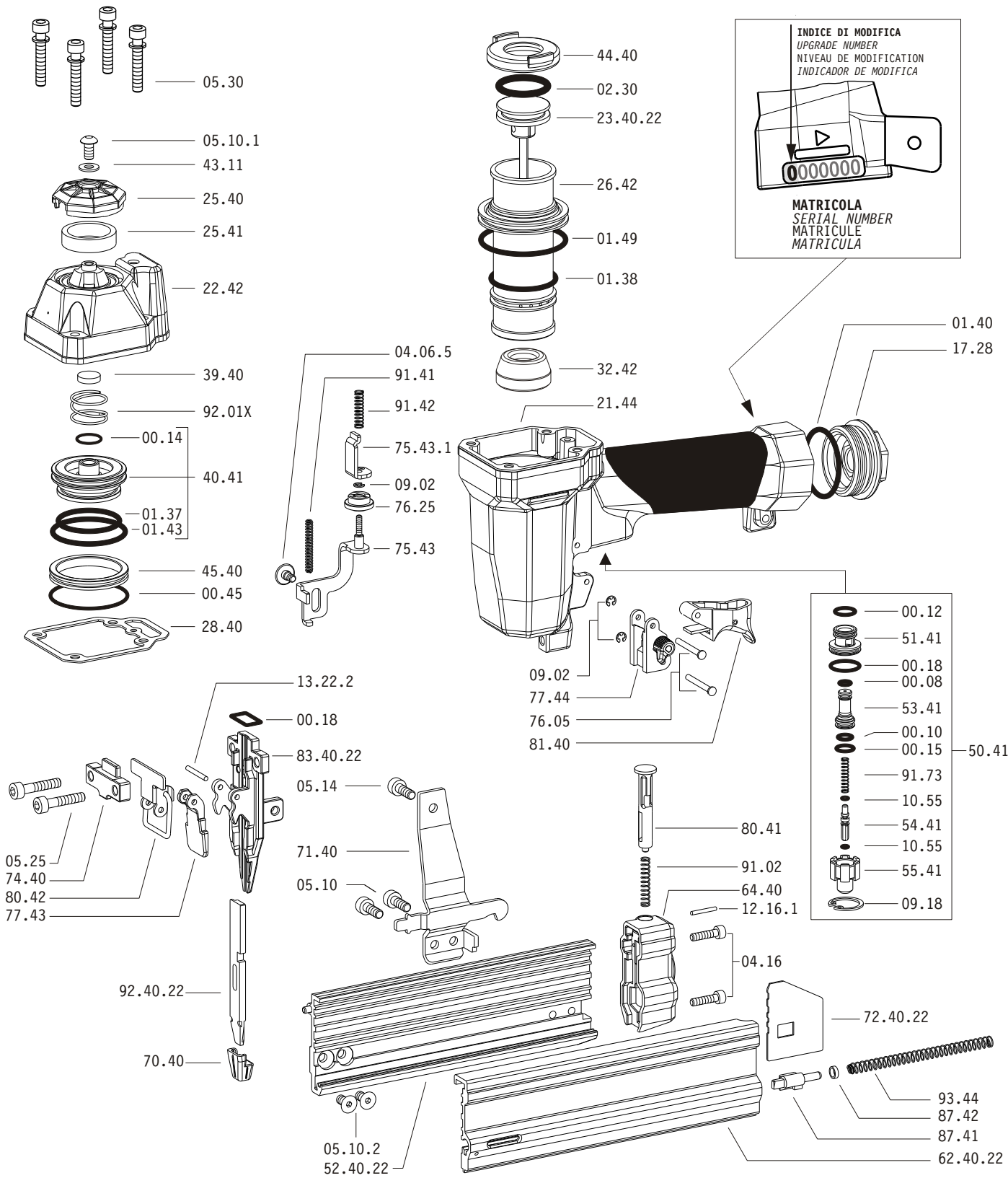

Dotazioni - Equipment - Ausrüstung - Équipements - Equipamiento -
Equipamento - Uitrusting - Udstyr



12.50

cod. 1421200

Parti di ricambio - Spare parts - Ersatzteile - Pièces de rechange - Piezas de repuesto
- Partes sobresselentes - Tabel te raadplegen - Reservedele

Cod.	Descrizione	Description
00.08	O-Ring	O-Ring
00.10	O-Ring	O-Ring
00.12	O-Ring	O-Ring
00.14	O-Ring	O-Ring
00.15	O-Ring	O-Ring
00.18	O-Ring	O-Ring
00.45	O-Ring	O-Ring
01.37	O-Ring	O-Ring
01.38	O-Ring	O-Ring
01.40	O-Ring	O-Ring
01.43	O-Ring	O-Ring
01.49	O-Ring	O-Ring
02.30	O-Ring	O-Ring
04.06.5	Vite	Screw
04.16	Vite	Screw
05.10	Vite	Screw
05.10.1	Vite	Screw
05.10.2	Vite	Screw
05.14	Vite	Screw
05.25	Vite	Screw
05.30	Vite	Screw
07.30	Chiave esagonale	Hex. bar wrench
07.40	Chiave esagonale	Hex. bar wrench
09.02	Anello elastico	Elastic ring
09.18	Anello elastico	Elastic ring
10.55	O-Ring	O-Ring
12.16.1	Spina	Pin
13.22.2	Spina	Pin
17.28	Tappo	Inlet cap
21.44	Corpo	Body
22.42	Testa	Head
25.40	Deflettore	Exhaust deflector
25.41	Silenziatore	Silencer
26.42	Cilindro	Cylinder
28.40	Guarnizione testa	Head gasket
32.42	Ammortizzatore	Bumper
39.40	Guarnizione scarico	Exhaust seal
40.41	Valvola completa	Valve ass'y
43.11	Rondella	Washer
44.40	Guarnizione	Gasket
45.40	Anello valvola	Ring
50.41	Pulsante completo	Trigger valve ass'y
51.41	Boccola pulsante	Trigger valve housing
53.41	Pistone servovalvola	Valve piston
54.41	Pulsante	Trigger valve
55.41	Raccordo pulsante	Bush
64.40	Fondello	Cap
70.40	Puntale	Contact tip
71.40	Reggicaricatore	Support
74.40	Staffa testina	Nose guide
75.43	Sicura	Safety
75.43.1	Rinvio sicura	Contact arm
76.05	Perno	Pin
76.25	Regolatore	Adjusting wheel
77.43	Guida testina	Safety nose plate
77.44	Guida sicura	Safety guide
80.41	Grilletto chiusura	Magazine lock trigger
80.42	Grilletto testina	Nose plate lock
81.40	Grilletto comando	Trigger
87.41	Portamolla	Spring bearing
87.42	Segnalatore	Signal washer
91.02	Molla	Spring
91.41	Molla	Spring
91.42	Molla	Spring
91.73	Molla	Spring
92.01X	Molla	Spring
93.44	Molla	Spring
23.40.22	Battente	Driver
52.40.22	Caricatore	Magazine
62.40.22	Carrello	Slider
72.40.22	Spingipunto	Pusher
83.40.22	Controtestina	Nose
92.40.22	Testina	Nose plate
D01	Bocchetta olio	Oiler

- Kit O-Rings - Pakninger

- Kit O-Rings - Dichtungen - Joints - Kit O-Rings -

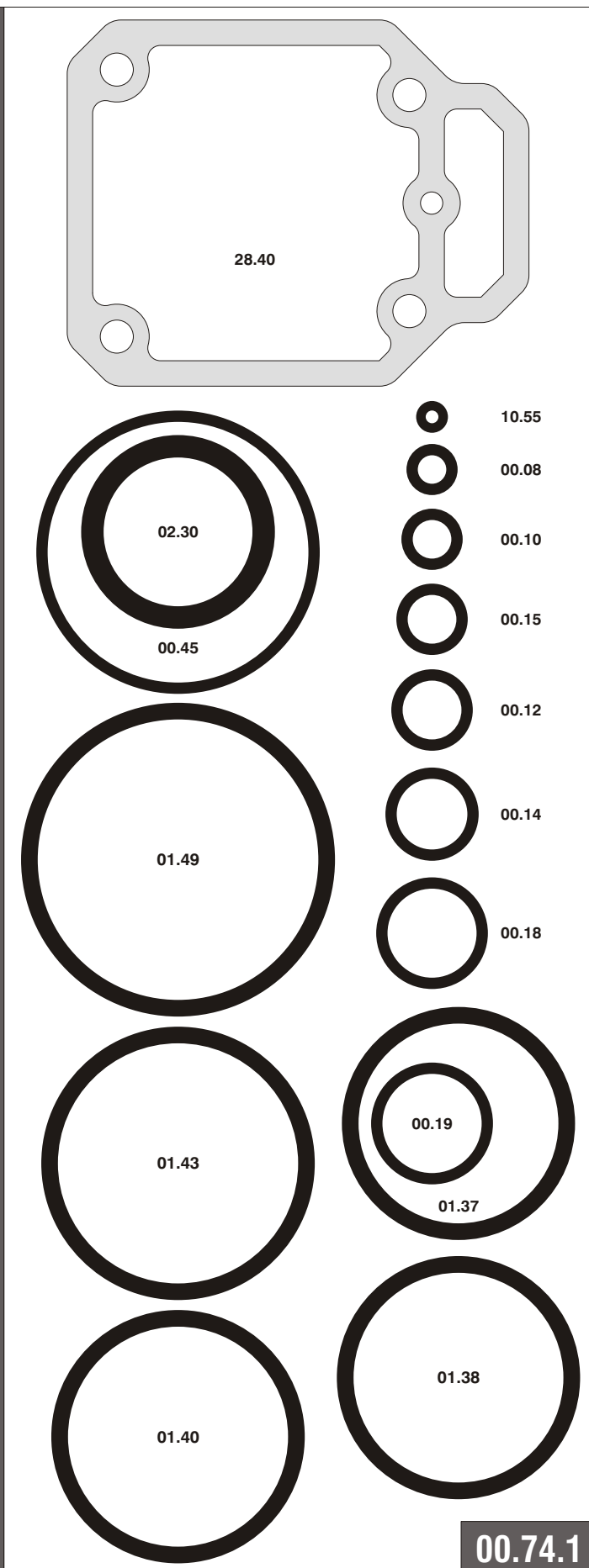

1421200_1250_2 220708 IV

12.50

cod. 1421200

Indice di modifica
Upgrade number

2